

# Antenna Installation Instructions

Part Number: HW4961-29.48D-HP







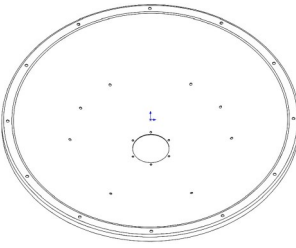
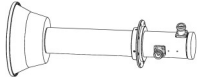
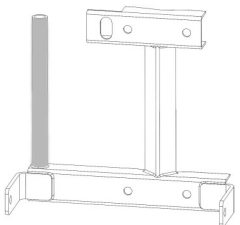

## Description

This antenna consists of a 0.6m (2ft) reflector, feeder and mount. The mount is designed to attach the antenna to a vertical pipe of diameter 35mm to 75mm. The mount provides adjustment ranges of  $\pm 15^\circ$  fine elevation and  $\pm 180^\circ$  azimuth. The unique feature of honorwave mount is the "Radio Installation Rod". The robust rod is compatible with all kind of radios (up to 45kg), make it easy to align antenna while radio is mounted on the rod.

## Notice

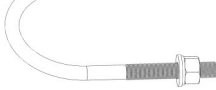
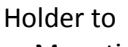

The installation, maintenance or removal of antenna systems requires qualified, experienced personnel. This installation instructions have been written for such personnel. Antenna systems should be inspected once a year by qualified personnel to verify proper installation, maintenance, and condition of equipment. Honorwave disclaims any liability or responsibility for the results of improper or unsafe installation practices.

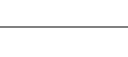
## Part List

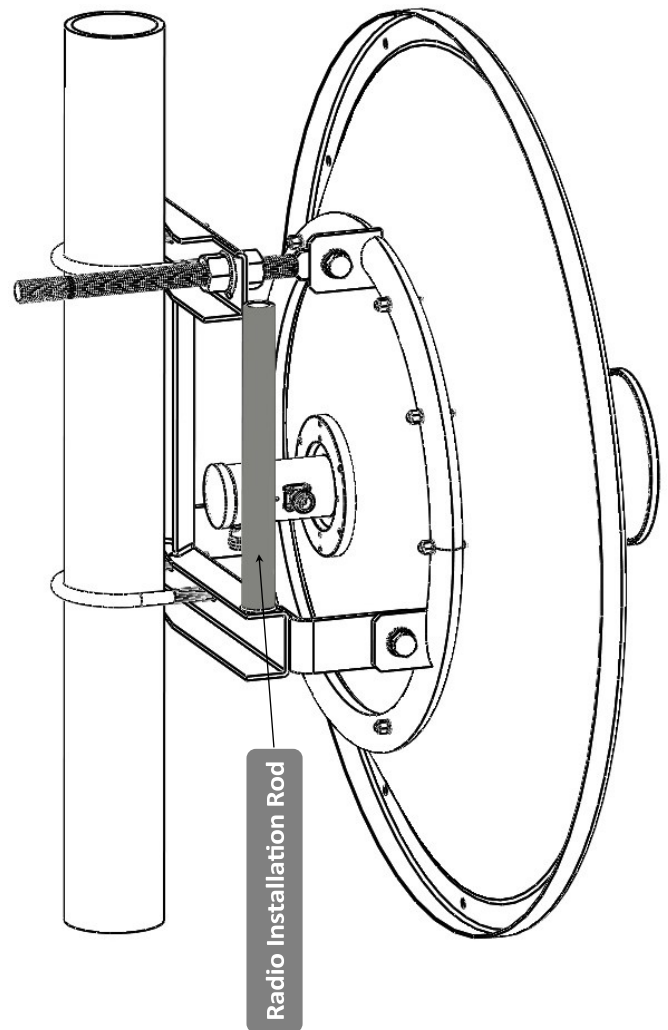
Item	Contents	Qty	Description / Image
A	Reflector 0.6m (2ft)	1	
B	Feeder	1	
C	T Shape Mounting With "Radio Installation Rod"	1	
D	Elevation Adjustment Screw	1	
E	Nut M16, galv	2	
F	Washer M16, galv	2	
G	U-Bolt M10x85, galv	2	
H	Nut M10, galv	4	
I	Spring Washer M10, galv	4	
J	Washer M10, galv	4	
K	Screw M10x30, Hex, galv	3	Holder to Ring Mounting 
L	Nut M10, galv	3	
M	Spring Washer M10, galv	3	
N	Washer M10, galv	3	Feed to Reflector 
O	Screw M4x12, Cross, st	4	
P	Spring Washer M4, st	4	
Q	Washer M4, st	4	
R	Inasalation Guide	1	



## Tools Required

Item	Contents	Qty	Image
1	Combination Wrench, 24mm	2	
2	Combination Wrench, 17mm	2	
3	Screwdriver, cross-recess	1	

## Installation

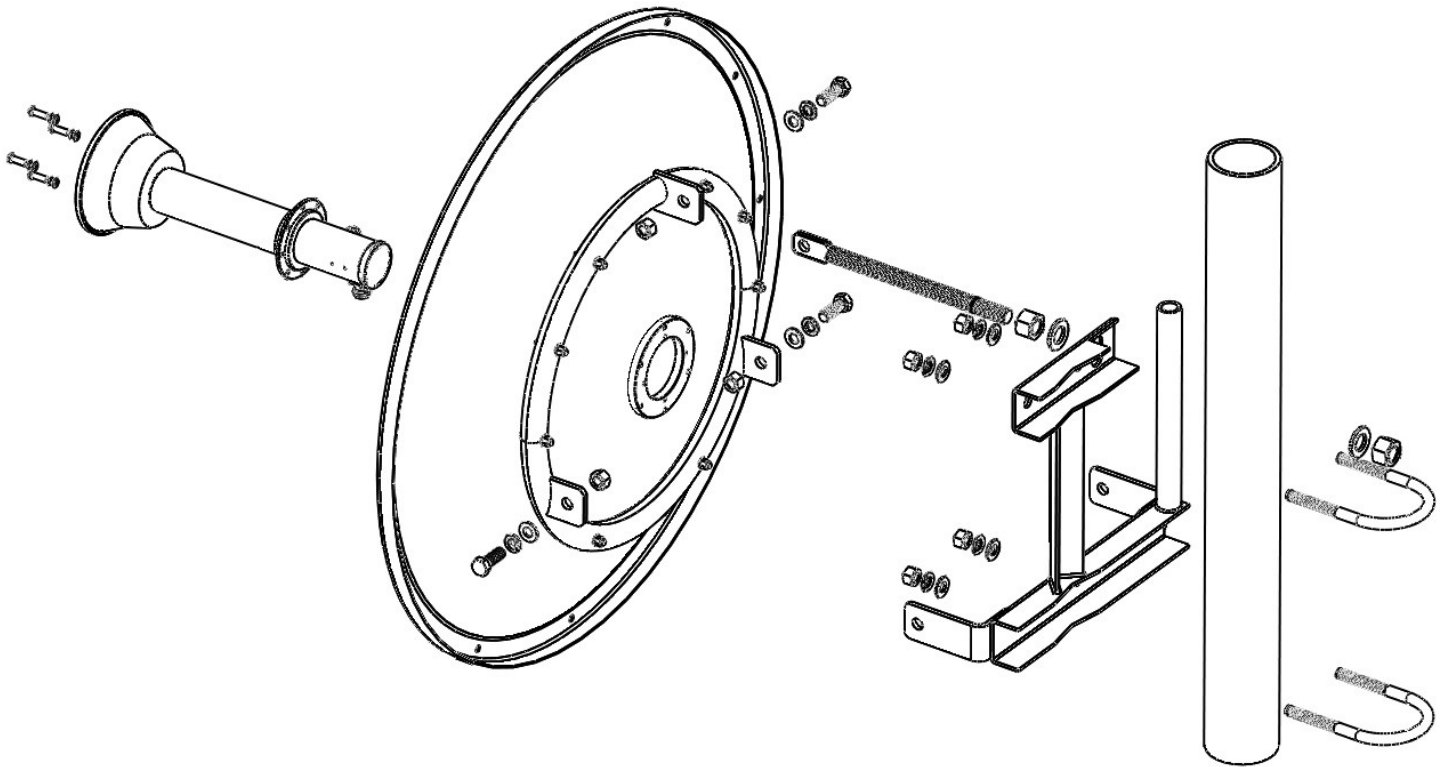

### 1 Install T-Shape Mounting and Elevation Adjustment Screw

Put Elevation Adjustment Screw [D] on the T-Shape Mounting [C]. Install T-Shape Mounting [C] and Elevation Adjustment Screw [D] to Reflector [A] by:

- [K] Screw M10x30; 3 pcs
- [L] Nut M10; 3 pcs
- [M] Spring Washer M10; 3 pcs
- [N] Washer M10; 3 pcs
- [E] Nut M16 x 2 pcs;
- [F] Washer M16 x 2 pcs.

Pivot Points should be loose to allow mounting frame to move so that Elevation Adjustment Screw [D] can be installed.

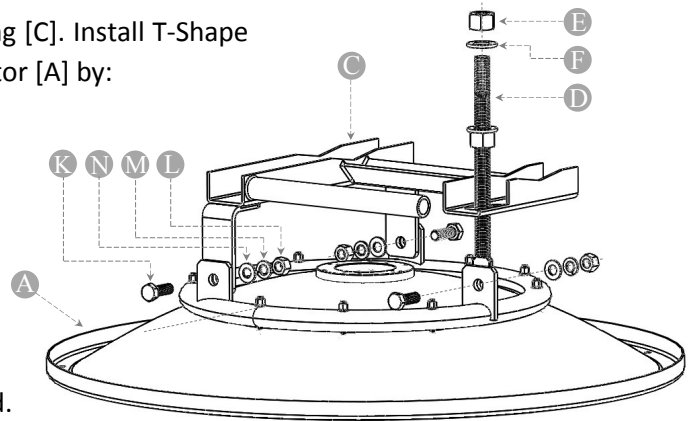

### 2 Install Feed to Reflector

Install Feed [B] to Reflector [A] by:

- [O] Screw M4x12; 4 pcs
- [P] Spring Washer M4; 4 pcs
- [Q] Washer M4; 4 pcs

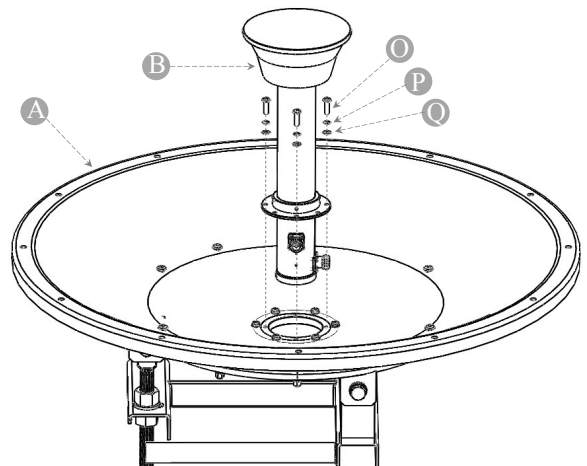

## 3 Attach Antenna to Mounting Pole

Select location for antenna and attach antenna to mounting pole by:

[G] U-Bolt M10x85; 2 pcs

[H] Nut M10; 4 pcs

[I] Spring Washer M10; 4 pcs

[J] Washer M10; 4 pcs

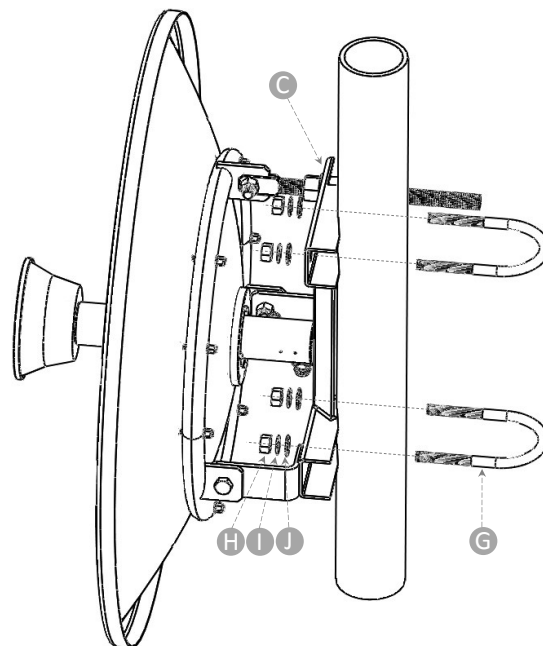

## 4 Adjust Azimuth and Elevation

After a visual alignment of both elevation and azimuth, azimuth can be adjusted by rotating the antenna while supported by the stabilizer bracket. Elevation is adjusted by tightening/loosening the elevation screw.

When azimuth/elevation are set tighten nuts to approximately 14N-m (10 lb-ft).

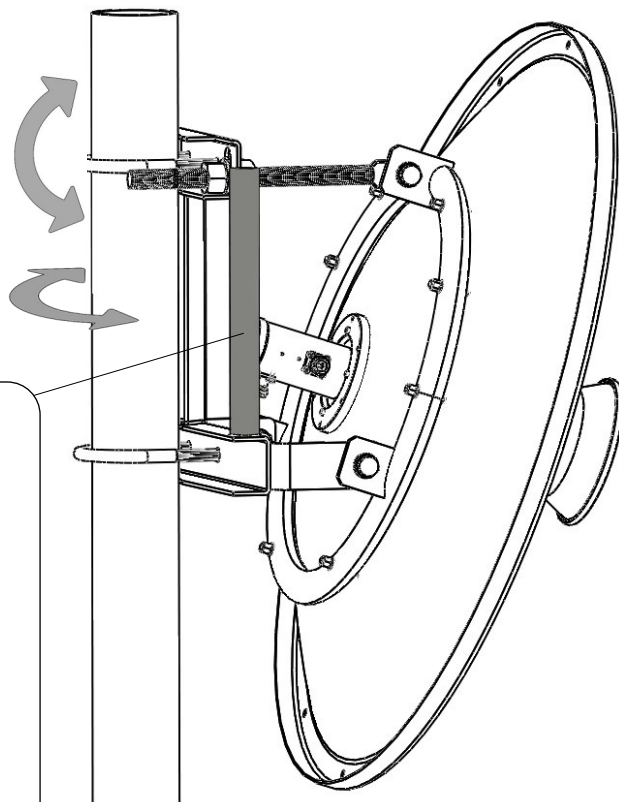

Important:

The Radio Installation Rod on the T-Shape Mounting [C] is to install any kind of radio box up to 45kg.

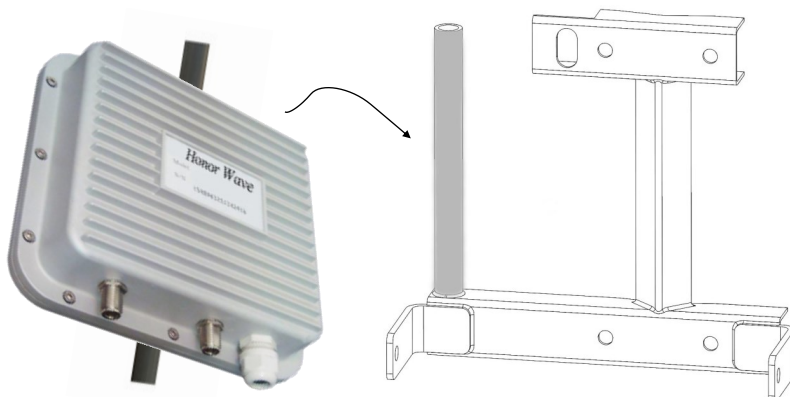

## TECHNICAL DATA SHEET

### General Specifications

Model Number	HW4961-29.48D-HP
Diameter (ft/m)	2/0.6
Polarization	Dual (Vertical and Horizontal)

### Electrical Specifications

Input	2 × N-Female
Frequency Range (MHz)	5 GHz ISM Band
VSWR	1.4:1
Impedance ( $\Omega$ )	50
Gain (dBi)	29.48
3dB Beamwidth	H-plane: 5° / E-plane: 5°
F/B Ratio (dB)	40

### Mechanical Specifications

Weight With Holder (kg)	5.5 kg
Color	Golden
Screws and Nuts	Galvanized and Steel
Fine Azimuth Adjustment	$\pm 15^\circ$
Wind Loading (km/h)	200
Operating Temperature	-40 °C to 60 °C
Supportable Comparative Damp	90%

### Patterns

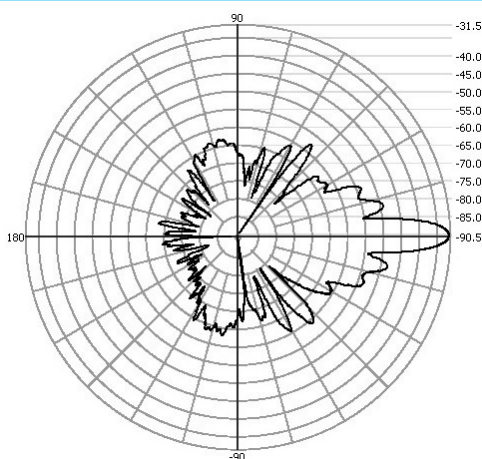

E-Plane

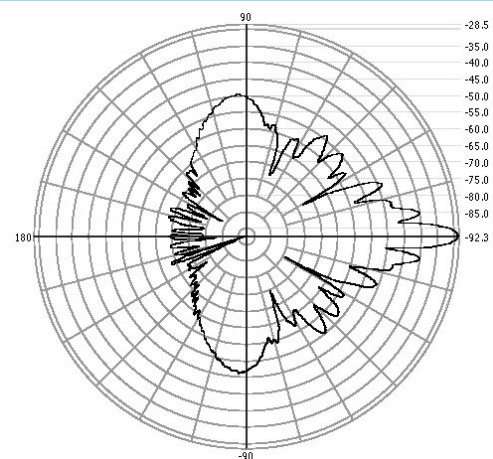

H-Plane

For further technical support leave message at

E-mail: [support@honorwave.com](mailto:support@honorwave.com)

whatsapp: +49 1520 7018 287 8 A.M - 5 P.M (GMT+2)

All messages will be answered in 2 working days.